

Sierra Safety Technology, Inc.

DCR1-A

UV/IR Acid/Solvent Resistant Flame Detector

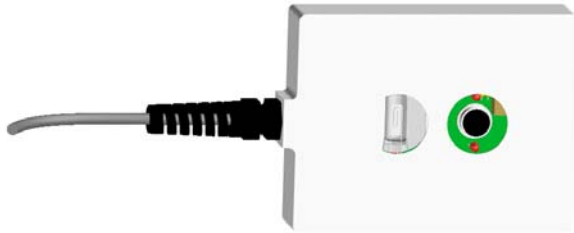

Features

- Meets or exceeds FM Specification Class Number 3260 (2002).
- Compatible with standard 4-wire interface.
- No moving parts or field modification required.
- Surfaces are smooth, non-shedding, scuff resistant, and accessible for wipe down.
- All surfaces are resistant to acids and solvents (i.e. hydrofluoric, sulfuric, phosphoric, nitric, and hydrochloric acids, de-ionized water, ammonium hydroxide, isopropyl alcohol, chromium phosphate, n-methyl-pyrrolidone, organic solvent base photo-resist strips, ozone, etc.).

Description

The DCR1 is designed for indoor applications where strong acids and solvents are employed, such as semiconductor manufacturing tools. The DCR1 has an ultrasonically welded FR rated polypropylene housing that was designed and tested to the IEC 529 IP67 rating for protection from a wide variety of acids and solvents. Consequently, periodic submersion will not damage the detector.

The DCR1 uses stable, proven UV/IR sensing technology. This allows the DCR1 to respond to the early stages of a fire without troublesome false alarms.

The DCR1 is rated over a wide operating temperature range for those applications where drying or heating elements are used. All models interface to most control panels and fire protection systems using industry standard relay contacts.

Specifications

Sensitivity 4 inch diameter isopropyl alcohol pan fire (on-axis) @ 10 feet within 3 seconds

Field of View 120° conical (NFPA)

False Alarm Immunity Does not alarm to sunlight, fluorescent lights, incandescent lights, flashlights, or infrared heaters

Housing An FR rated Polypropylene (IEC 529 IP67) housing with a 6' pigtail (8 wires standard). Detector housing meet UL 94 flammability rating V0

Input voltage range 12 to 32 volts DC @ 28 ma

Operating Temperature -40° to 85° C

Operating Humidity 10% to 90%

Footprint 3.4 in. wide by 4.2 in. long by 1 in. thick

Tested Fuels Gasoline (Heptane), Polypropylene, Isopropyl Alcohol, MEK, Hydrogen, and Silane

LEDs 2 red LEDs - Indicate either Normal, Trouble or Alarm status

Alarm Relay 1.0 Amp @ 30 VDC resistive

Trouble Relay 1.0 Amp @ 30 VDC resistive

Spectral Sensitivity Solar-blind UV sensor that responds to radiant energy in the 185 to 260 nm band and a Solid State IR Sensor that responds to IR energy in the .715 to 3.5 um band

Self-Test Models Incorporate an internal self-test

Enhanced Models Incorporate an internal self-test and a RS485 computer interface for downloading real time spectral data and pre-fire spectral data.

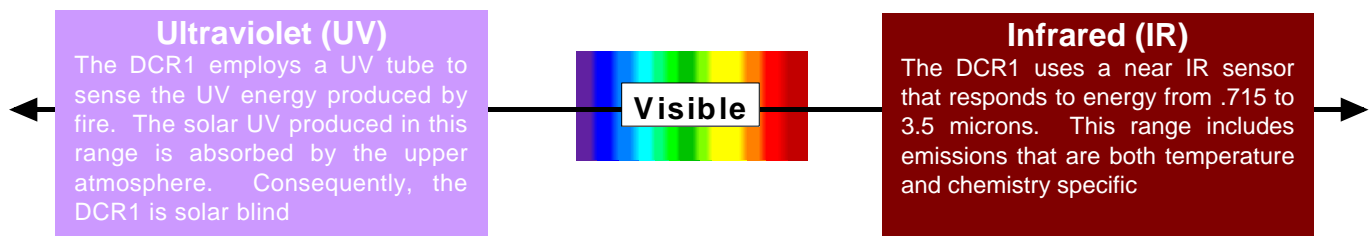

False Alarm And Fire Response

This table shows the detectors ability to tolerate both modulated and unmodulated false alarm stimuli and still to detect a fire in the presence of the false alarm source (all fire tests used a 1.75" diameter alcohol pan fire at 6 feet).

False Alarm Source	Distance	Unmodulated	Modulated	Response Time To Fire
Resistive Electric Heater 1320 Watt	6 Feet	No Response	No Response	Less than 3 Seconds
Fluorescent Lights 2 40 Watt Bulbs	6 Feet	No Response	No Response	Less than 3 Seconds
Halogen Light 500 Watt	10 Feet	No Response	No Response	Less than 3 Seconds
Incandescent Light 100 Watt	6 Feet	No Response	No Response	Less than 3 Seconds

Detector Response To Various Fuels

Fuels	Distance	Fire Size	Response Time
Polypropylene	8 feet	4 inch diameter	Less than 3 Seconds
Isopropyl Alcohol	10 feet	4 inch diameter	Less than 3 Seconds
Heptane	40 feet	1 square foot	Less than 3 Seconds
MEK	15 Feet	4 inch diameter	Less than 3 Seconds
Silane	30 feet	18 inch jet	Less than 3 Seconds
Hydrogen	15 Feet	18 inch jet	Less than 3 Seconds

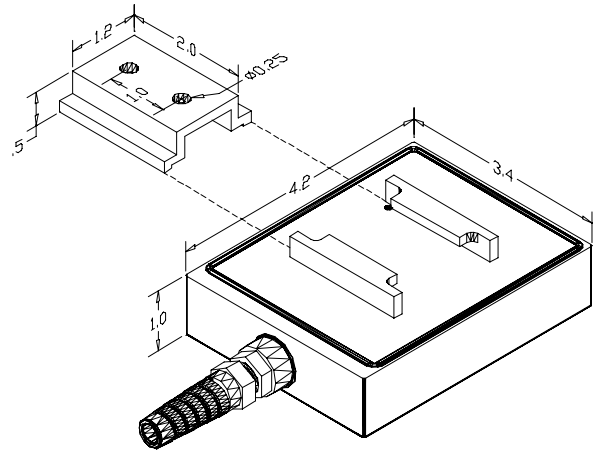

Dimensions
(In inches)

Field Of View

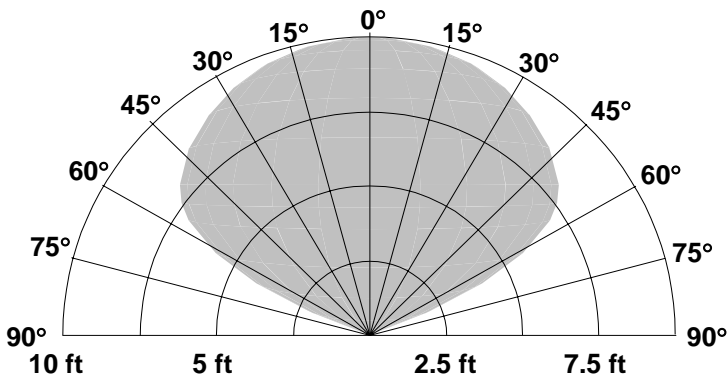

Notes: NC stands for normally closed and NO for normally open trouble relay operation.

Ordering Information

Model #	Configuration	Housing	Fault Relay
DCR1-AS1	Standard	FRPP	NC
DCR1-AS3	Standard	FRPP	NO
DCR1-AT1	Self Test	FRPP	NC
DCR1-AT3	Self Test	FRPP	NO
DCR1-AE1	Enhanced	FRPP	NC
DCR1-AE3	Enhanced	FRPP	NO
DCR1-AM	Special Cable	FRPP	NC