

DCR1

**Models S1 KS1, S3, KS3, T1, KT1, T3,
KT3, E1, KE1, E3, and KE3**

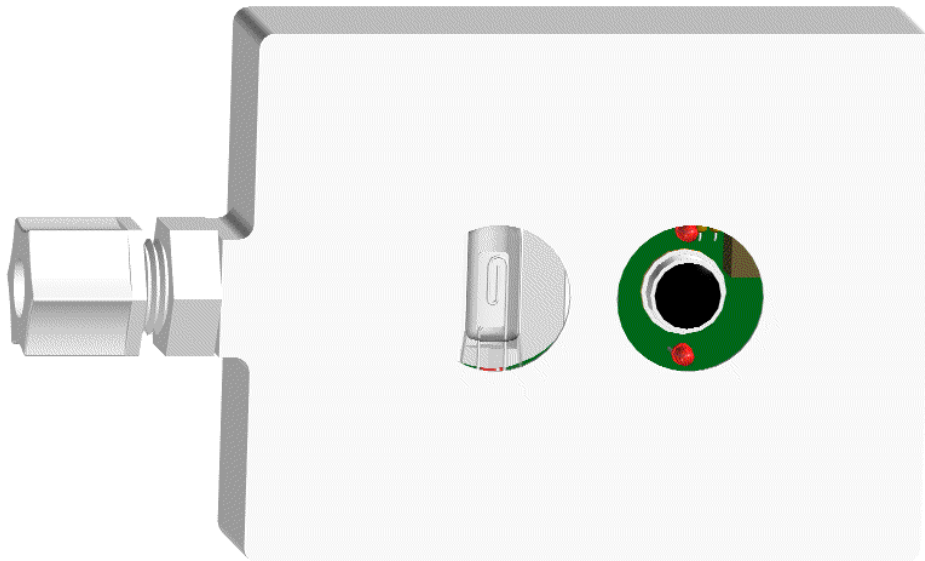

**Technical Support And Installation
Manual**



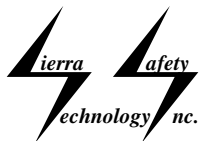

Sierra Safety Technology, Inc.

Installer's Manual

1. OVERVIEW	1
2. BASIC OPERATION	1
2.1 General	1
2.2 Field-of-View	2
2.3 Range	2
2.4 Environment	2
2.5 Configuration	2
2.6 LED operation	3
2.7 Relay operation	4
3. INSTALLATION	5
3.1 Housing	5
3.2 Connection	5
3.3 Testing	6
4. MAINTENANCE	7
4.1 Lens Cleaning	7
5. GENERAL SPECIFICATIONS	8
FIGURES	9
Figure 1 - DCR1 Housing Dimensions	9
Figure 2 - DCR1 Cabling	9
Figure 3 - DCR1 Layout	10
Figure 4 - DCR1 Wiring	10
Figure 5 - DCR1 Field-of-View	11
7. TABLES	12
7.1 Cable Wiring	12
7.2 Relay Configurations	12
7.3 Fault Table	12
8. TROUBLESHOOTING	14
8.1 No LED blink or erratic LED blink	14
8.2 Detector Indicates Fault	14
8.3 Device appears to operate normally but will not alarm to a fire.	15



Sierra Safety Technology, Inc.

Installer's Manual

1. Overview

The DCR1 provides reliable flame detection for the interior spaces of production and cleaning equipment. The DCR1 is a mid-range flame detector sealed in an Ultra-Sonically welded plastic housing impervious to a broad range of acids and other materials found in production equipment. Many of applications for this device, for example, are found in process tools in the Semiconductor Industry. All versions of the DCR1 Flame Detector utilize UV and IR sensors to look for flaming combustion. The DCR1 Flame Detector is a microprocessor-controlled device programmed with state-of-the-art fire algorithms. Each algorithm is designed to recognize a different type of flame signature while rejecting common false alarm sources. When the conditions of the fire algorithms are met the DCR1 Detector declares a fire. See tables 7.4 and 7.5 for detectors ability to reject false alarm stimuli and its response to various fuels.

The microprocessor is also continuously performing system tests looking for faults that would impair its ability to detect a flame and declare an alarm. These tests include: input power, sensor circuits, relay circuits, as well as other internal systems. The DCR1 has both a Fire Relay and a Fault Relay, the Fault Relay may be ordered as either normally open or normally closed contacts.

The DCR1 detector has an IP67 sealed polypropylene (FRPP) or polyvinylidene fluoride (PVDF) housing. The housing is fitted with a 1/4 npt fitting for a 3/8-inch diameter teflon, polypropylene or PVDF tube. The cabling is run inside the tube and must be sealed by using a fitting at a j-box or the plenum wall.

2. Basic Operation

2.1 General

When the DCR1 Detector is powered up, the microprocessor checks the detector with a series of self-tests. After the self-test process is complete and all tests are passed, the detector is ready to detect a fire. The power-up and test process may take up to 10 seconds.

All modes of operation are indicated by two LEDs located on the front of the detector. Normal Mode is indicated by a brief flash of the LEDs every 8 seconds. With the device in Normal Mode it is constantly monitoring the environment and ready to detect a fire.

When a fire is detected the DCR1 will activate the Fire Relay and turn on both LEDs. The detector then stores the pre-fire spectral data in memory. This is the Alarm Mode and the device will remain in this mode until power is removed.



Sierra Safety Technology, Inc.

Installer's Manual

The self-test system is continuously monitoring the internal systems. If a fault is detected the Fault Relay is de-energized. When the detector is in a Fault Mode the LEDs will flash a code indicating the type of fault. A fault indication may mean the device is being operated in an unsafe manner, unable to detect a fire or that a device has become unreliable (i.e. a "Voltage Low" fault). For most faults the detector will return to Normal Mode when the fault condition is corrected.

2.2 Field-of-View

Optical Flame Detectors must be able to "see" the fire to declare an alarm. Any obstruction between the detector and the threat area will impair the detector's ability to cover the threat area. An obstruction is anything that is not transparent to the sensor elements of the detector. This would include glass or plastics. The DCR1 series of Flame Detectors has a 120° Field of View.

When covering a large area the detectors should be located to provide overlapping fields of view to insure complete coverage.

2.3 Range

The fuel and ambient conditions may affect the sensitivity of a detector. The DCR1 is tested to a 4-inch diameter isopropyl alcohol fire at a distance of 10 feet. Using the inverse square of the distance rule, if the device will detect a 4-inch fire at 10 feet, to detect a 1/4-size fire (approximately 2-inch diameter) the devices must be within 5 feet. The nominal speed of response is 3 seconds.

2.4 Environment

The DCR1 Detector uses an Ultraviolet sensor (185-260 nanometers) and an Infrared sensor (0.715-3 microns). This detector senses all radiant energy at these frequencies within their Field-of-View. Any source that radiates energy at these same frequencies may impact the detector's ability to discriminate against false alarms. Care should be taken to minimize such radiant energy sources within the detectors Field-of-View. Because of the variety of environments and conditions, a factory trained technician or qualified Professional Engineer should be consulted before deciding on the location of devices.

2.5 Configuration

All models of the DCR1 detector are configured at the factory. The connections for Normally Open or Normally Closed operation are made internally and cannot be changed.

The DCR1 comes in several configurations and several models. Each model may be ordered with the any of the relay configurations listed in



Sierra Safety Technology, Inc.

Installer's Manual

"Chart 2". All models of the DCR1 have the same detection and false alarm rejection capability. The "S" or standard model was designed for simple and reliable operation at the least expense. The "T" or self-test model has a built in self-test circuit for the sensors. This added self-test improves reliability and reduces regular maintenance. Chart 1 below shows the features of each model. In addition to the features of the "T" model the "E" model includes the ability to communicate with and external computer. This permits the downloading of a DataScan™ or FireScope™ from the detector

Model	Built in Sensor self-test	Housing Type	Blinks
DCR1-Sx	NO	Polypropylene	1
DCR1-Tx	YES	Polypropylene	2
DCR1-Ex	YES	Polypropylene	3
DCR1-KSx	NO	Polyvinylidene Fluoride	1
DCR1-KTx	YES	Polyvinylidene Fluoride	2
DCR1-KEx	YES	Polyvinylidene Fluoride	3

Chart 1
DCR1 models

Configuration	Fire Relay Contacts	Fault Relay Contacts*	Blinks
DCR1-x1	Normally Open	Normally Closed	1
DCR1-x3	Normally Open	Normally Open	3

Chart 2
Relay configurations

(*This is with the detector operating normally and the Fault relay energized)

2.6 LED operation

The status of all versions of the DCR1 detectors can be determined from the LEDs located behind the lens on the front of the detector. The LEDs will flash at intervals or remain on to indicate the detector's status. (Fault Mode, Normal Mode, Alarm Mode)

2.6.1 Power Up

At power up all versions of the DCR1 detector will begin by flashing the LEDs in a pattern indicating the model and configuration. The first LED will turn on while the second LED blinks a number of times. The number of times the second LED blinks defines the model of the DCR1 (see Chart 1). Both LEDs will then turn off. Then the First LED will turn on again while the second LED blinks a number. The number of times the second LED blinks indicates the relay configuration of the DCR1 (see Chart 2).



Sierra Safety Technology, Inc.

Installer's Manual

After the configuration pattern the LEDs will flash once every 8 seconds while in normal mode. If the detector is powered up and a fault is detected the LEDs will flash in a pattern indicating the type of fault.

2.6.2 Normal

In Normal Mode the LEDs will flash briefly every 8 seconds. Whenever the device is in any other mode the “flash every 8 seconds” is suspended until the detector returns to Normal Mode.

2.6.3 Fire

When the DCR1 declares a fire both LEDs will come "on" and the Fire Relay will energize. The detector will stay in alarm mode until power is removed.

2.6.4 Fault

When the detector has power and is in Fault Mode LED1 (the left LED when facing the detector with the cable below the LEDs) will be “off” while the LED2 (the right LED) will begin flashing, 1/2 second “on” and 1/2 second “off”, a number of times. The number of times LED2 flashes indicates the level of fault. LED2 will stop flashing and LED1 will turn “on”. This cycle is repeated until the fault is corrected. See Fault table 7.3 for levels of fault. Only the lowest level fault is indicated. Once a fault is corrected the next level fault will be indicated until all faults are cured. Except for fault level 2 or 3, a fire indication will override a fault indication.

2.7 Relay operation

All Models of the DCR1 have two relays. One Fire Relay for indicating fire conditions and one Fault Relay for indicating detector fault conditions.

2.7.1 Fire Relay

The Fire Relay will energize when the detector declares a fire. The Fire Relay will remain energized until power is removed from the DCR1.

2.7.2 Fault Relay

The Fault Relay is a normally energized relay. It will de-energize when a Fault occurs. This means the detectors Fault Relay is in the “Fault” state when the detector has no power, and remains in the “Fault” state until the detector is powered up and operating normally.



3. Installation

3.1 Housing

3.1.1 Mounting the Housing

The housing is mounted by using the bracket located on the back of the housing. The detector should be mounted securely to a flat surface. The preferable orientation of the detector is for the cable to exit from the bottom. Remove the bracket from the housing by sliding the bracket down. The bracket may be welded (plastic weld) or screwed to the mounting surface. Mounting hardware should be compatible with the agents that may be found in the environment. The mounting location must be strong enough to allow the detector to be snapped into place. Although the detector is not vibration sensitive the detector should not be exposed to excessive vibration. The detector meets the vibration standard set in FM's Approval Standard Class 3820, Sept. 1979. (.022" displacement, 10 Hz to 30 Hz sweep cycled at 2 cpm for 4 hours)

3.1.2 Wiring

The cabling is encased within a tube. Mount a 3/8 tubing fitting into the wall where the cabling is to be run through or to a junction box. Cut the tubing to fit. Secure the tubing as needed for the application. Run the cabling to the connections of the controller or junction box. Care should be exercised not to put excessive strain on the tube ends. Strain on the tube ends may allow fluid to enter the housing.

In addition, both tube fittings must be adequately tightened to prevent fluid from entering the detector housing.

3.2 Connection

All connections are made at the cable end. Connect the cable wiring to the appropriate connection points in the controller or junction box. See the chart 7.1 for wiring.

3.2.1 Power

Supply power must be "OFF" before connecting the DCR1 Detector. Power for the DCR1 detector is connected to the Red and Black wires in the cable. Connect the Red wire to the positive side of the 24VDC supply. Connect the Black wire to the negative side of the 24VDC supply. Check the controller manufacturer's manual for proper connection points.



Sierra Safety Technology, Inc.

Installer's Manual

3.2.2 Fire Relay

The Fire Relay is connected with the Blue, Orange, Brown, and Yellow wires in the cable (see figure 4). Connect the Blue wire to one side of the Fire Signal Circuit and the Orange wire to the other side of the Fire Signal Circuit. Connect the Brown wire to the Blue wire of the next detector and the Yellow wire to the Orange wire of the next detector in the chain. Connect the EOL resistor across the Brown and Yellow wires on the last detector in a chain. The Fire Relay wires are not polarized. The Blue and Brown wires are connected internally to one side of the Fire Relay and the Orange and Yellow wires are connected internally to the other side of the Fire Relay. Refer to the controller manufacturer's manual for proper connection points and value of EOL resistor.

3.2.3 Fault Relay

The Fault Relay is connected with the White and Green wires in the cable. Connect the White wire to one side of the Fault Signal Circuit and the Green wire to the other side of the Fault Signal Circuit or to the Green wire of the next device if more than one device is being used. The Fault Relay wires are not polarized. Refer to the controller manufacturer's manual for proper connection points.

3.3 Testing

The DCR1 detector uses ongoing self-test functions, which will indicate a fault if any of the functions fail to pass. If an end-to-end test is required the detector may be made to alarm with a butane-lighter (Bic) with a flame approximately 1 inch high. Hold the lighter about 2 feet directly in front of detector's face. Light the lighter and wiggle it about 1/2 inch at about 2 - 4 Hz. The detector should alarm within 3 seconds. A 4-in. diameter pan with isopropyl alcohol set 10 feet away may also be used. If you choose to use this method, the detector field of view should be blocked until the fire has achieved maximum size. Remove the shield. The detector should alarm within 3 seconds. The DCR1 may also be tested using a factory-approved hand held tester. Hold the tester approximately 2 feet directly in front of the detector. Activate the tester. The detector should alarm within 3 seconds.

NOTE: Because of the danger involved with fire testing, please exercise CAUTION and observe All safety procedures. If an extinguishing system is present, make sure to disable the outputs to the extinguishing system prior to testing. After testing, re-enable the extinguishing system outputs.



Sierra Safety Technology, Inc.

Installer's Manual

4. Maintenance

If a detector indicates a fault, use the troubleshooting section of this document to correct the fault. Contact the local "authority having jurisdiction" or consult the local codes for any maintenance they may require for the type of system installed. The detector should be tested quarterly or more frequently as required by local codes.

4.1 Lens Cleaning

To clean the lens: Wipe the lens surface with a clean lint free cloth. If more extensive cleaning is required then use denatured or Isopropyl alcohol and a clean lint free cloth to clean the lens. Do not use any silica-based solvents. (Most common glass cleaners are silica based and should not be used to clean the lens.)



Sierra Safety Technology, Inc.

Installer's Manual

5. General Specifications

Input voltage: 12 to 32 Volts DC, typically 24 Volts DC

Current draw: @ 24 Volts DC: 28 ma normal mode, 54 ma alarm mode

Temperature Range: -40° to 85° Celsius

Relay contacts: 1.0 Amp @ 30 VDC resistive

Connections: 24 gauge, 8-wire cable standard. (6' standard length)

Weight: Approximately 1 pound

Housing:

Dimensions: 3.4" x 4.2" x 1"

Material: FR Polypropylene (UL 94 flammability rating V0) or polyvinylidene fluoride (PVDF)

Rating: IP67

Sensitivity:

Spectral Responsivity: UV - 185 to 260 nanometers
IR - 715 to 3500 nanometers

Range: within 3 seconds to a 4-in. diameter isopropyl alcohol fire at 10 feet.

Field-of-View: 120° full cone

6. Figures

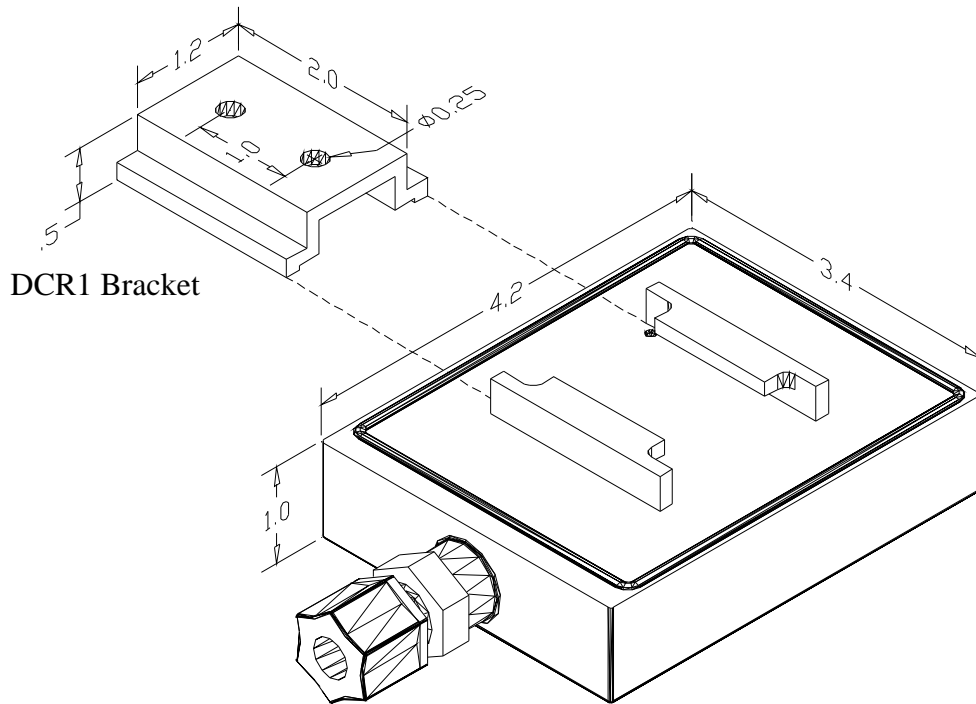

Figure 1
DCR1 Housing Dimensions

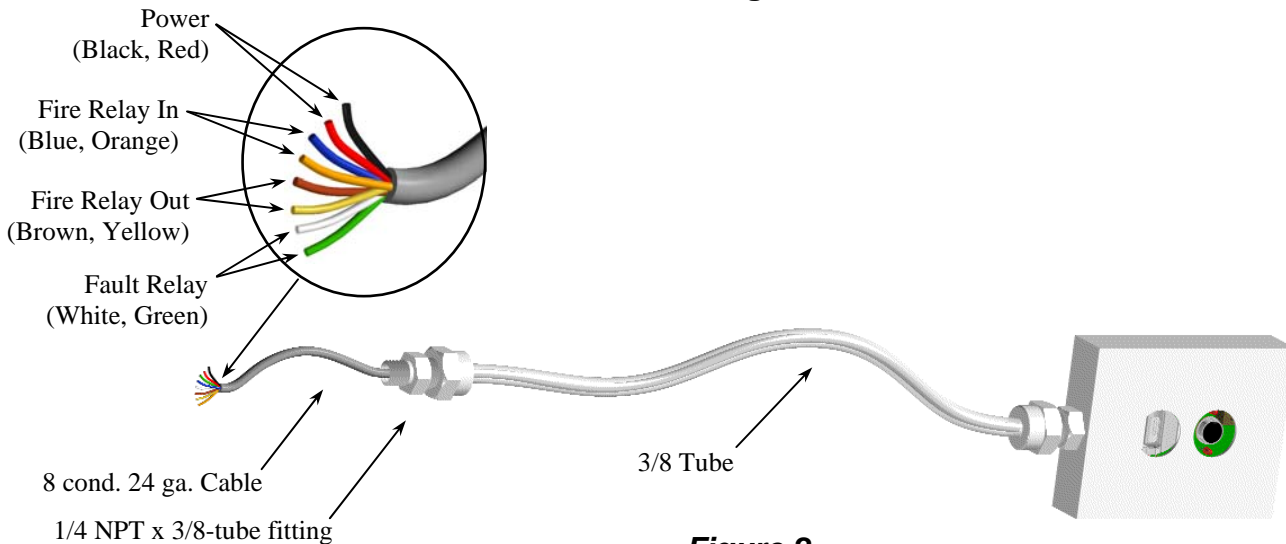

Figure 2
DCR1-Sx, -KSx, -Tx, and -KTx Cabling

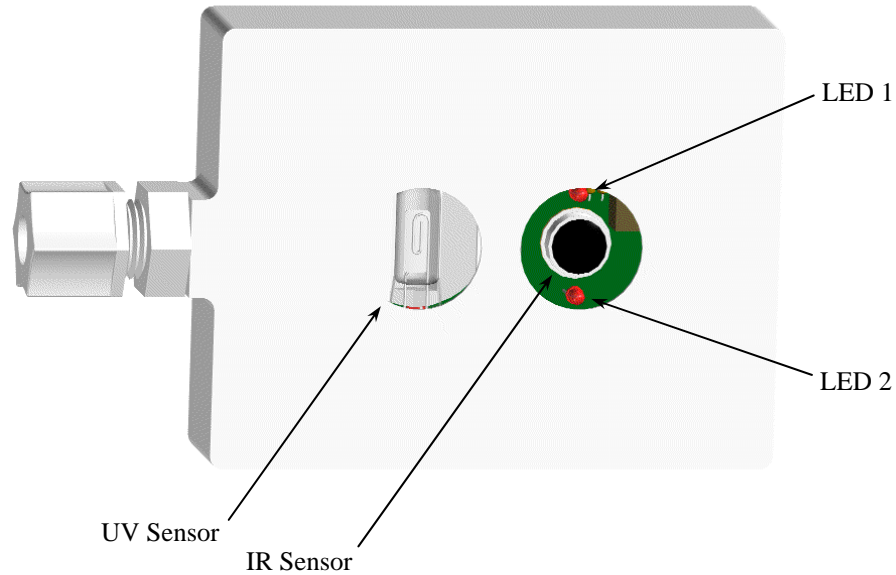

Figure 3
DCR1 Layout (Sensor & LEDs)

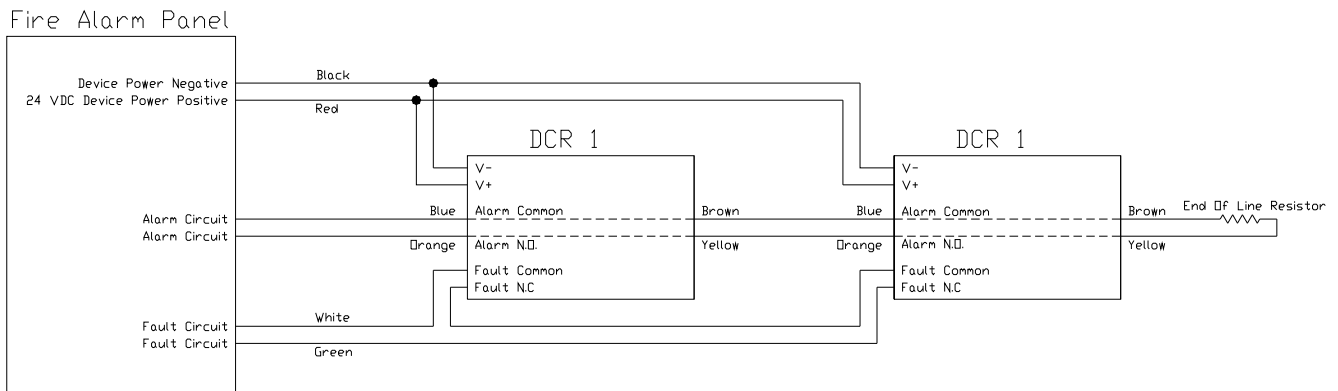

Figure 4
DCR1-Sx -KSx, -Tx, and -KTx Wiring

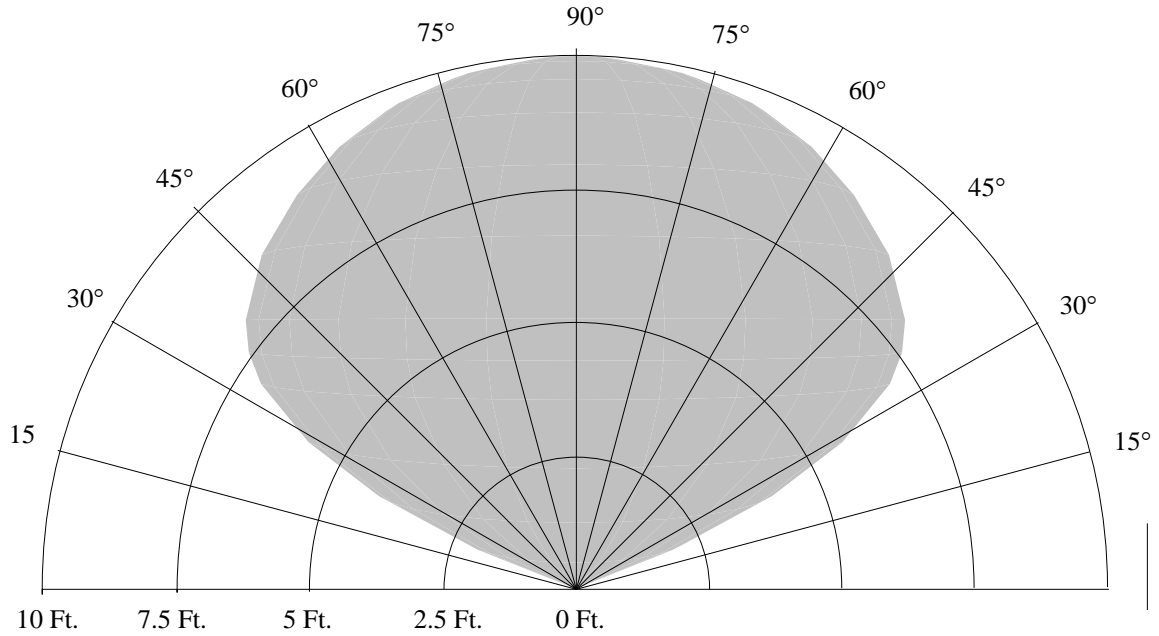

Figure 5
DCR1 Field-of-View
for a 4" dia. alcohol fire



Sierra Safety Technology, Inc.

Installer's Manual

7. Tables

7.1 Cable Wiring

Wire	Description	Internal Connection
Red	Positive power 12 to 30 VDC	+
Black	Negative side of power	-
Blue	Fire Relay In	Fire relay common
Orange	Fire Relay In	Fire relay NO
Brown	Fire Relay Out	Fire relay common
Yellow	Fire Relay Out	Fire relay NO
White	Fault Relay	Fault relay Common
Green	Fault Relay	Fault relay NC or NO
Purple ¹	RS485 A	"A"
Grey ¹	RS485 B	"B"

1) Only applies to the DCR1-Ex models.

7.2 Relay Configurations

Model #	Fire Relay	Fault Relay
DCR1 - x1	Open Contacts	Closed Contacts
DCR1 - x3	Open Contacts	Open Contacts

7.3 Fault Table

Fault #	Fault Label	Description
1	UV Test Fault (DCR1-T or -E only)	UV sensors didn't detect enough UV from the internal UV source
2	Program Failure	The program sum check is in error
3	Calibration Fault	Device is out of calibration
4	Voltage Low	Input Voltage is below 12 VDC
5	Photo. Sensor Fault	IR sensor failed to detect internal test source.
6	Relay Fault	Relay coil circuit is open.
7	Volt. High	Input Voltage was above 32 VDC
8	Temp. Out of Range	Internal device temperature went below -40° C or above 85° C.

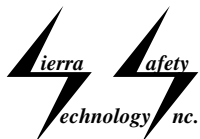

Sierra Safety Technology, Inc.

Installer's Manual

7.4 False Alarm Stimuli Table

This table shows the detectors ability to reject both modulated and unmodulated false alarm stimuli.

False Alarm Source	Distance	Unmodulated	Modulated
Resistive Electric Heater 1320 Watt	6 Feet	No Response	No Response
Fluorescent Lights 2 40 Watt Bulbs	6 Feet	No Response	No Response
Halogen Light 500 Watt	10 Feet	No Response	No Response
Incandescent Light 100 Watt	6 Feet	No Response	No Response

7.5 Fire Response Table

Detector Response To Various Fuels			
Fuel	Distance	Fire Size	Response Time
Polypropylene	8 feet	4 inch diameter	Less than 3 Seconds
Isopropyl Alcohol (IPA)	10 feet	4 inch diameter	Less than 3 Seconds
Heptane	40 feet	1 square foot	Less than 3 Seconds
MEK	15 Feet	4 inch diameter	Less than 3 Seconds
Silane	30 feet	18 inch jet	Less than 3 Seconds
Hydrogen	15 Feet	18 inch jet	Less than 3 Seconds



8. Troubleshooting

The DCR1 detector has several built-in self-test mechanisms that verify function and calibration. The following procedure covers most faults and problems, which may occur during installation or during the course of normal operation.

8.1 *No LED blink or erratic LED blink*

With power connected to the detector the LEDs on the front of the detector module should begin blinking and blink about every 8 seconds. If they do not blink or blink in an abnormal fashion then;

1. Check voltage at power connections. The Red wire should be positive; the Black wire should be negative. There should be between 12 and 32 volts DC across the Red and Black wires.
2. If main power is correct and the detector is not indicating a fault then the detector should be returned to the factory.

8.2 *Detector Indicates Fault*

Use the fault table to determine what type of fault is occurring and see appropriate section below to correct. If the corrective actions listed below do not correct the fault, contact the factory for further diagnostic instructions or instructions on returning the detector for servicing.

8.2.1 **Fault Type 1 - "UV Test Fault" (One blink of LED2)**

During the UV self-test there the UV sensor didn't see enough UV from the UV source. This test is available on the -T and -E versions. Factory service is required.

8.2.2 **Fault Type 2 – "Program Failure Fault" (Two blink of LED2)**

The program has been damaged.
Factory service is required.

8.2.3 **Fault Type 3 - "Calibration Fault" (Three blink of LED2)**

Calibration constants have been corrupted.
Factory service is required.

8.2.4 **Fault Type 4 - "Voltage Low Fault" (Four blink of LED2)**

The input voltage is below 12 VDC. With the detector connected to power, measure the voltage between the Red wire and the Black wire on the cable. The voltage should be between 12 - 32 VDC. If the voltage is out of range check external wiring and power supply. There should not be more than 1 volt of AC ripple at 24 VDC. If the measured voltage is in range and there is no AC ripple. Contact the factory for return and service information.



Sierra Safety Technology, Inc.

Installer's Manual

8.2.5 Fault Type 5 - "Photo Sensor Fault" (Five blink of LED2)

The IR Sensors did not pass the internal self-test. If the lens is clean. The fault may be in the sensors or the self-test circuit. This test is only available on the -T and -E versions. Contact the factory for further diagnostic information.

8.2.6 Fault Type 6 - "Relay Fault" (Six blink of LED2)

One of the Relay's coil circuits is open. There is no corrective action. Contact the factory for return and service information.

8.2.7 Fault Type 7 - "Voltage High" (Seven blink of LED2)

The Detector was exposed to an input voltage above 32 Volts. There is no corrective action. Contact the factory for return and service information.

8.2.8 Fault Type 8 - "Temperature Out of Range" (Eight blink of LED2)

The internal measured temperature was below -40° C or above 85° C. There is no corrective action. Contact the factory for return and service information.

8.3 *Device appears to operate normally but will not alarm to a fire.*

When the detector declares an alarm two things should happen. One, both the LEDs on the front of the detector should come on. Two, the fire relay should energize. Connect an ohmmeter across the Fire relay wires (Green and Blue) at the cable. Run a fire test per section 3.3.

1. If the relay closes (0 ohms on the meter) and the LEDs come on the detector is operating normally. Check external alarm initiating circuit wiring.
2. If the relay closes and the LEDs remain off, or the relay remains open and the LEDs come on, the detector needs factory service.
3. If the relay remains open and the LEDs remain off, contact the factory for further diagnostic information.



Sierra Safety Technology, Inc.

Installer's Manual

INDEX

Alarm

Mode, 1, 3

Cleaning, 7

Connection, 5

Current draw, 8

DCR1, 1, 2, 3, 4, 6, 7, 14

Fault, 4

Relay, 1, 2, 4, 6

Field-of-View, 2, 8

Fire, 4

Relay, 1, 4, 6

Testing, 7

Housing, 5, 8

Infrared, 2

Input voltage, 8

LEDs, 1, 3, 4, 15

Lens, 7

Mode

Alarm, 1, 3, 4

Fault, 4

Normal, 1, 2, 3

Normal Mode, 1, 2, 3, 4

Power, 3, 6, 14

Range, 2, 8

Relay, 4, 12

Contacts, 8

Fault, 1, 2, 4, 6

Fire, 1, 4, 6

Sensitivity, 8

Field-of-View, 8

Range, 2

Temperature Range, 8

Testing, 7

Ultraviolet, 2

Wiring, 5, 8, 12